



U
S

OWNER'S/OPERATOR'S MANUAL

CHAINSAW

GZ4000

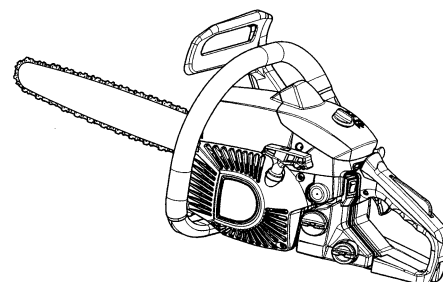

⚠ WARNING ⚠

The engine exhaust from this product contains chemicals known to the State of California to cause cancer, birth defects or other reproductive harm.

⚠ WARNING ⚠

Before using our products, please read this manual carefully to understand the proper use of your unit.

APPLICABLE SERIAL NUMBERS :

720401 and up

SAFETY FIRST

Instructions contained in warnings within this manual marked with a  symbol concern critical points which must be taken into consideration to prevent possible serious bodily injury, and for this reason you are requested to read all such instructions carefully and follow them without fail.



■ WARNINGS IN THE MANUAL

WARNING

This mark indicates instructions which must be followed in order to prevent accidents which could lead to serious bodily injury or death.

IMPORTANT

This mark indicates instructions which must be followed, or it leads to mechanical failure, breakdown, or damage.

NOTE

This mark indicates hints or directions useful in the use of the product.

Contents

1. Parts location	3
2. Specifications	3
3. Warning labels on the machine	4
4. Symbols on the machine	4
5. For safe operation	5
6. Installing guide bar and saw chain	7
7. Fuel and chain oil.....	8
8. Operation	10
9. Sawing.....	13
10. Maintenance	15
11. Maintenance of saw chain and guide Bar	17
12. Storage	18
13. Disposal	18
14. Troubleshooting guide	18

1. Parts location

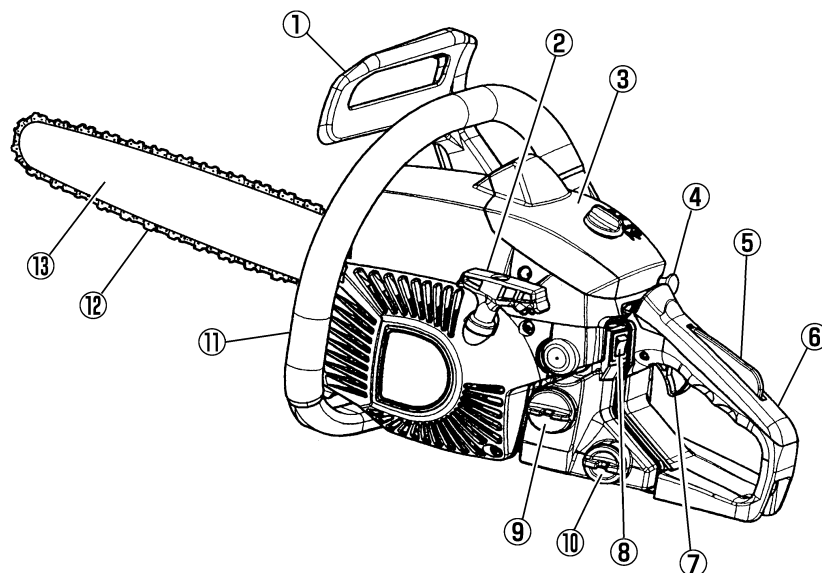

1. Front guard
2. Starter knob
3. Air cleaner cover
4. Choke knob
5. Throttle interlock
6. Right handle
7. Throttle lever
8. Engine switch
9. Fuel tank
10. Oil tank
11. Left handle
12. Saw chain
13. Guide Bar

2. Specifications

■ GZ4000

Power unit :

Displacement	2.45(40.1) cu-in(cm ³)
Fuel	Mixture(Gasoline 50 : 2-cycle oil 1) (when using RedMax genuine oil)
Fuel tank capacity	10.4(0.31) fl.oz (ℓ)
Chain oil	Motor oil SAE #10W-30
Oil tank capacity	7.10(0.21) fl.oz (ℓ)
Carburetor	Diaphragm type (ZAMA C1Q)
Ignition system	Pointless (CDI)
Spark plug	Champion RZ7C
Oil feeding system	Automatic pump
Power	1.84/9,500 (kw/min ⁻¹)
Max speed	13,000 (min ⁻¹)
Idle speed	2,700 (min ⁻¹)
Sprocket : Pitch – No. of teeth	3/8in(9.53mm) – 6T
Dimensions : L – W – H	14.8(370)x9.4(235)x10.8(270) in(mm)
Dry weight : Power unit only	9.5(4.3) lbs(kg)

Cutting attachment :

Guide bar : Type – Size	Sprocket nose – 14(35) in(cm)
Saw chain : Type – Pitch – Gauge	Oregon 91VG – 3/8(9.53) – 0.050(1.27) in(mm)

Specifications are subject to change without notice.

3. Warning labels on the machine

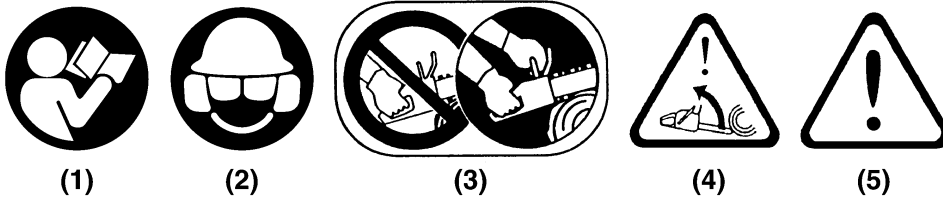





- (1) Read operator's instruction book before operating this machine.
- (2) Wear head, eye and ear protection.
- (3) Use the chain saw with two hands.
- (4) Warning! Danger of kickback.
- (5) Read, understand and follow all warnings.

4. Symbols on the machine

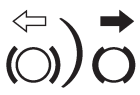
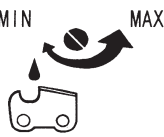

For safe operation and maintenance, symbols are carved in relief on the machine. According to these indications, please be careful not to make any mistake.

- (a)  (a) The port to refuel "MIX GASOLINE"
Position: Fuel cap
- (b)  (b) The port to top up chain oil
Position: Oil cap
- (c)  (c) Setting the switch to the "O" position, the engine stops immediately.
Position: Rear-left of the unit
- (d)  (d) Starting the engine. If you pull out the choke knob (at the back-right of the rear handle) to the point of the arrow, you can set the starting mode as follows:
 - *First-stage position – starting mode when the engine is warm.*
 - *Second-stage position – starting mode when the engine is cold.***Position:** Upper-right of the aircleaner cover
- (e)  (e) The screw under the "H" stamp is The High-speed adjustment screw. The screw under the "L" stamp is The Slow-speed adjustment screw. The screw at the left of the "T" stamp is the Idle adjustment screw.
Position: Left side of the rear handle
- (f)  (f) Shows the directions that the chain brake is released (white arrow) and activated (black arrow).
Position: Front of the chain cover
- (g)  (g) If you turn the rod by screwdriver follow the arrow to the "MAX" position, the chain oil flow more, and if you turn to the "MIN" position, less.
Position: Bottom of the power unit

■ EMISSION CONTROL

An emission control label is located on the engine.

EMISSION CONTROL INFORMATION

THIS ENGINE MEETS U.S. EPA AND CALIFORNIA EXH/EVP REGS FOR 2009*1 S.O.R.E.
 ENGINE FAMILY : 9HQZS.0404FG*2 DISPL.: 40cc
 EMISSION CONTROL SYSTEM : EXH;EM
 COMPLIANCE PERIOD : 125 HOURS
 REFER TO OPERATOR'S MANUAL FOR MAINTENANCE, SPECIFICATIONS AND ADJUSTMENTS.
MANUFACTURED:
 USE JASO FD OR ISO L-EGD GRADE 50:1 OIL
 Husqvarna Zenoah Co., Ltd.

*1: The year will be changed every year of manufacturing.

*2: The initial number will be changed every year of manufacturing.

▲ 5. For safe operation



1. Never operate a chain saw when you are fatigued, ill, or upset, or under the influence of medication that may make you drowsy, or if you are under the influence of alcohol or drugs.

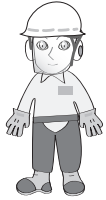

2. Use safety footwear, snug fitting clothing and eye, hearing and head protection devices.

Use the vibration-proof glove.

3. Keep the saw chain sharp and the saw, including the AV system, well maintained. A dull chain will increase cutting time, and pressing a dull chain through wood will increase the vibrations transmitted to your hands. A saw with loose components or with damaged or worn AV buffers will also tend to have higher vibration levels.

4. All the above mentioned precautions do not guarantee that you will not sustain whitefinger disease or carpal tunnel syndrome. Therefore, continual and regular users should monitor closely the condition of their hands and fingers. If any of the above symptoms appear, seek medical advice immediately.

5. Always use caution when handling fuel. Wipe up all spills and then move the chain saw at least 3 m from the fueling point before starting the engine.



6. Eliminate all sources of sparks or flame (i.e. smoking, open flames, or work that can cause sparks) in the areas where fuel is mixed, poured, or stored.



7. Do not smoke while handling fuel or while operating the chain saw.

8. Do not allow other persons to be near the chain saw when starting or cutting. Keep bystanders and animals out of the work area. Children, pets and bystanders should be a minimum of 10 m away when you start or operate the chain saw.

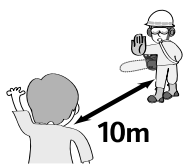

9. Never start cutting until you have a clear work area, secure footing, and a planned retreat path from the falling tree.

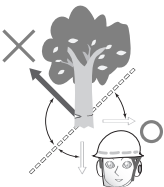

10. Always hold the chain saw firmly with both hands when the engine is running. Use a firm grip with thumb and fingers encircling the chain saw handles.

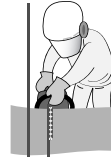

11. Keep all parts of your body away from the saw chain when the engine is running.



12. Before you start the engine, make sure the saw chain is not contacting anything.

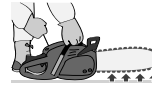

13. Always carry the chain saw with the engine stopped, the guide bar and saw chain to the rear, and the muffler away from your body.

14. Always inspect the chain saw before each use for worn, loose, or damaged parts. Never operate a chain saw that is damaged, improperly adjusted, or is not completely and securely assembled. Be sure that the saw chain stops moving when the throttle control trigger is released.



15. All chain saw service, other than the items listed in the Owner's Manual, should be performed by competent chain saw service personnel. (E.g., if improper tools are used to remove the flywheel, or if an improper tool is used to hold the flywheel in order to remove the clutch, structural damage to the flywheel could occur which could subsequently cause the flywheel to disintegrate.)



16. Always shut off the engine before setting it down.

17. Use extreme caution when cutting small size brush and saplings because slender material may catch the saw chain and be whipped toward you or pull you off balance.



18. When cutting a limb that is under tension, be alert for spring-back so that you will not be struck when the tension in the wood fibers is released.

19. Never cut in high wind, bad weather, when visibility is poor or in very high or low temperatures. Always check the tree for dead branches which could fall during the felling operation.



20. Keep the handles dry, clean and free of oil or fuel mixture.

21. Operate the chain saw only in well ventilated areas. Never start or run the engine inside a closed room or building. Exhaust fumes contain dangerous carbon monoxide.



▲ 5. For safe operation



22. Do not operate the chain saw in a tree unless specially trained to do so.
23. Guard against kickback. Kickback is the upward motion of the guide bar which occurs when the saw chain at the nose of the guide bar contacts an object. Kickback can lead to dangerous loss of control of the chain saw.



24. When transporting your chain saw, make sure the appropriate guide bar scabbard is in place.



- (5) Do not overreach or cut above shoulder height.

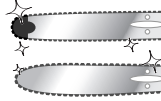

- (6) Follow the manufacturer's sharpening and maintenance instructions for the saw chain.
- (7) Only use replacement bars and chains specified by the manufacturer or the equivalent.

KICKBACK SAFETY PRECAUTIONS FOR CHAIN SAW USERS

▲ WARNING

- Kickback may occur when the nose or tip of the guide bar touches an object, or when the wood closes in and pinches the saw chain in the cut. Tip contact in some cases may cause a lightning fast reverse reaction, kicking the guide bar up and back towards the operator. Pinching the saw chain along the top of the guide bar may push the guide bar rapidly back towards the operator. Either of these reactions may cause you to lose control of the saw, which could result in serious personal injury.
- Do not rely exclusively on the safety devices built into your saw. As a chain saw user you should take several steps to keep cutting jobs free from accident or injury.



- (1) With a basic understanding of kickback you can reduce or eliminate the element of surprise. Sudden surprise contributes to accidents.
- (2) Keep a good grip on the saw with both hands, the right hand on the rear handle, and the left hand on the front handle, when the engine is running. Use a firm grip with thumbs and fingers encircling the chain saw handles. A firm grip will help you reduce kickback and maintain control of the saw.



- (3) Make certain that the area in which you are cutting is free from obstructions. Do not let the nose of the guide bar contact a log, branch, or any other obstruction which could be hit while you are operating the saw.
- (4) Cut at high engine speeds.

6. Installing guide bar and saw chain

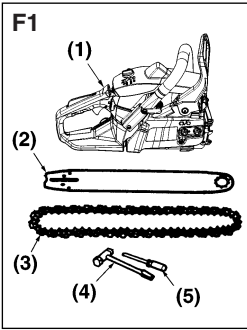

■ A standard saw unit package contains the items as illustrated. (F1)

- (1) Power unit
- (2) Guide bar
- (3) Saw chain
- (4) Plug wrench
- (5) Screwdriver for carburetor adjustment

Open the box and install the guide bar and the saw chain on the power unit as follows:

⚠ WARNING

The saw chain has very sharp edges. Use thick protective gloves for safety.

1. Pull the guard towards the front handle to check that the chain brake is not engaged.
2. Loosen the nuts and remove the chain cover.
3. Gear the chain to the sprocket and, while fitting the saw chain around the guide bar, mount the guide bar to the power unit. Adjust the position of the chain tensioner. (F2)

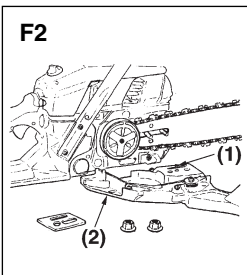

- (1) Tensioner nut
- (2) Chain cover

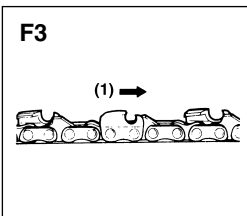

📖 NOTE

Pay attention to the correct direction of the saw chain. (F3)

- (1) Moving Direction

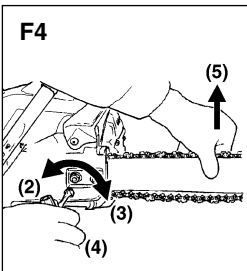

4. Fit the chain cover to the power unit and fasten the nuts to finger tightness.
5. While holding up the tip of the bar, adjust the chain tension by turning the tensioner screw until the tie straps just touch the bottom side of the bar rail. (F4)
6. Tighten the nuts securely with the bar tip held up (12~15 N·m). Then check the chain for smooth rotation and proper tension while moving it by hand. If necessary, readjust with the chain cover loose.
7. Tighten the tensioner screw.

- (2) Loosen
- (3) Tighten

- (4) Tensioner screw
- (5) Lift up

📖 NOTE

A new chain will expand its length in the beginning of use. Check and readjust the tension frequently as a loose chain can easily derail or cause rapid wear of itself and the guide bar.

7. Fuel and Chain Oil

■ FUEL

▲ WARNING

- Gasoline is very flammable. Avoid smoking or bringing any flame or sparks near fuel. Make sure to stop the engine and allow it cool before refueling the unit. Select outdoor bare ground for fueling and move at least 10 ft (3 m) away from the fueling point before starting the engine.



■ GASOLINE REQUIREMENTS

- All 2-Stroke RedMax Products are powered by RedMax Professional-Commercial Duty, Hi-Performance, Hi-RPM, Air Cooled 2-Stroke engines. RedMax – Hi-Performance 2-stroke engines produce higher HP outputs as compared to standard Home Owner Duty or Light Commercial Duty production engines offered by most manufacturers.
- Exhaust emission are controlled by the fundamental engine parameters and components (eq., carburation, ignition timing and port timing) without addition of any major hardware or the introduction of an inert material during combustion.
- The RedMax Engines are registered and certified with CARB (California Air Resources Board) and EPA (Environmental Protection Agency) to operate on CLEAN Mid-grade 89 octane or Premium, unleaded (lead-free) gasoline and RedMax Air-Cooled "Max Life", Synthetic blend Premium two-stroke engine oil mixed at 50:1 ratio.
- Unleaded gasoline is recommended to reduce the contamination of the air for the sake of your health and the environment.
- This Hi-Performance Air Cooled 2-stroke Engine requires the use of **Minimum** 89 Octane $\left[\frac{R+M}{2} \right]$ (Mid grade or Premium) clean gasoline. Gasoline may contain maximum of 10% Ethanol (grain alcohol) or up to 15% MTBE (Methyl tertiary-butyl ether). Gasoline containing Methanol (Wood Alcohol) is **NOT** approved.

NOTE

- If octane rating of the Mid Grade gasoline in your area is lower than 89 Octane use Premium Unleaded Gasoline. The majority of all 2-stroke engine manufacturers in the USA and Canada recommend using gasoline with 89 Octane or higher.

▲ WARNING

- Gasoline with an octane rating lower than 89 will greatly increase the engines operating temperature. Low octane gasoline will cause detonation (knock) resulting in piston seizures and major internal engine components damage.
- Poor quality gasolines or oils may damage sealing rings, fuel

lines or fuel tank of the engine.

NOTE

- Failures caused by operating engines on gasoline with octane rating lower than 89 are not covered by the RedMax Two-Stroke engine warranty.

▲ WARNING

- Alternative Fuels (Not Gasoline)**
Alternative fuels, such as E-15 (15% ethanol), E-20 (20% ethanol), E-85 (85% ethanol) are **NOT** classified as gasoline and are **NOT** approved for use in RedMax 2-stroke gasoline engines. Use of alternative fuels will cause major engine performance and durability problems such as: improper clutch engagements, overheating, vapor lock, power loss, lubrication deficiency, deterioration of fuel lines, gaskets and internal carburetor components, etc... Alternative fuels cause high moisture absorption into the fuel/oil mixture leading to oil and fuel separation.

■ OIL REQUIREMENTS

- Use only RedMax "Max Life", Synthetic blend Premium Air-Cooled two-stroke engine oil or oil certified to ISO-L-**EGD** (ISO/CD1378) standard AND one that is **JASO-FD** registered. RedMax Air-Cooled "Max Life", Synthetic blend Premium two stroke engine oil and ISO-L-**EGD** (ISO/CD1378) AND **JASO-FD** oils are fully compatible with gasoline's containing 10% Ethanol. RedMax Air-Cooled "Max Life", Synthetic blend Premium two stroke engine oil and ISO-L-**EGD** (ISO/CD1378) AND **JASO-FD** oils are **Universal** and should be mixed at 50:1 ratio for all 2 stroke air cooled engines sold in the past regardless of mixing ratios specified in those manuals.
- If the oil is registered with JASO, the JASO Logo with **FD** and registration number will be displayed on the container. The highest JASO rating is "FD", which equals the ISO-L-**EGD** rating. Lower ratings are "FC", "FB", and "FA".



- Engine problems due to inadequate lubrication caused by failure to use ISO-L-**EGD** certified and JASO **FD** registered oil such as "MaxLife", RedMax Synthetic blend Premium 2-stroke oil **WILL VOID THE REDMAX TWO-STROKE ENGINE WARRANTY.**

▲ WARNING

- Do not use NMMA (National Marine Manufacturers Association), BIA (Boating Industry Association), and TCW (two cycle water cooled) oils designed for MoPeds or Outboard, water cooled Marine Engines. Do not use API (American Petroleum Institute), TC (Two Cycle) labeled oils. The API-TC

7. Fuel and Chain Oil

test standard has been discontinued by API in 1995 and it no longer exists.

IMPORTANT

Gasoline/Oil mixture Storage Recommendations

Store your gasoline or gasoline/oil mixture in a cool dry area in a tightly sealed approved container to limit the entry of moisture and additional air (oxygen). Moisture and air cause the development of varnish and gum, making the fuel stale. Stored gasoline and gasoline/oil mixture ages and loses its octane rating and volatility. Do not mix more gasoline/oil than you intend to use in 30 days, and 60 days when fuel stabilizer is added. RedMax Air-Cooled "Max Life" Synthetic blend Premium two-stroke engine oil "**Contains fuel stabilizer**" and will automatically extend your gasoline/oil mixture life up to 60 days.

HOW TO MIX FUEL

RECOMMENDED MIXING RATIO

GASOLINE 50 : OIL 1

(when using RedMax Air-Cooled "Max Life")

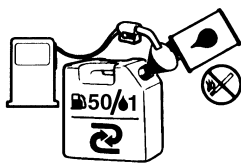

50:1 MIXING CHART

GASOLINE	gal.	1	2	3	4	5
2-CYCLE OIL	fl.oz	2.6	5.2	7.8	10.4	13

GASOLINE	liter	1	2	3	4	5
2-CYCLE OIL	ml	20	40	60	80	100

WARNING

Pay attention to agitation.

1. Measure out the quantities of gasoline and oil to be mixed.
2. Put some of the gasoline into a clean, approved fuel container.
3. Pour in all of the oil and agitate well for 10seconds.
4. Pour in the rest of gasoline and agitate again for at least one minute. As some oils may be difficult to agitate depending on oil ingredients, sufficient agitation is necessary. Be careful that, if the agitation is insufficient, there is an increased danger of early piston seizure due to abnormally lean mixture.
5. Place a clear indication on the outside of the container to avoid mixing up with gasoline or other containers that dont contain oil.
6. Indicate the contents on outside of container for easy identification.

FUELING THE UNIT

1. Untwist and remove the fuel cap. Rest the cap on a clean surface.
2. Put fuel into the fuel tank to 80% of the full capacity.
3. Fasten the fuel cap securely and wipe up any fuel spillage around the unit.

WARNING

1. Select flat and bare ground for fueling.
2. Move at least 10 feet (3 meters) away from the fueling point before starting the engine.
3. Stop the engine before refueling the unit. At that time, be sure to sufficiently agitate the mixed gasoline in the container.

FOR YOUR ENGINE LIFE, AVOID

1. FUEL WITH NO OIL (RAW GASOLINE) – It will cause severe damage to the internal engine parts very quickly.
2. GASOHOL – It can cause deterioration of rubber and/or plastic parts and disruption of engine lubrication.
3. OIL FOR 4-CYCLE ENGINE USE – It can cause spark plug fouling, exhaust port blocking, or piston ring seizure.
4. **Mixed fuels which have been left unused for a period of one month or more** may clog the carburetor and result in the engine failing to operate properly.
5. In the case of storing the product for a long period of time, clean the fuel tank after rendering it empty. Next, Start the engine and run the carburetor dry residual fuel.
6. In the case of scrapping the used mixed oil container, scrap it only at an authorized depository site.

NOTE

- As for details of quality assurance, read the description in the section Limited Warranty carefully. Moreover, normal wear and change in product with no functional influence are not covered by the warranty. Also, be careful that, if the usage in the instruction manual is not observed as to the mixed gasoline, type of oil or fuel to be used. described therein, it may not be covered by the warranty.

CHAIN OIL

Use motor oil SAE #10W-30 all year round or SAE #30 ~ #40 in summer and SAE #20 in winter.

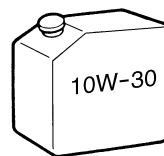

NOTE

Do not use wasted or regenerated oil that can cause damage to the oil pump.

8. Operation

⚠ WARNING

It is very dangerous to run a chainsaw that mounts broken parts or lacks any parts.

Before starting engine, make sure that all the parts including bar and chain are installed properly.

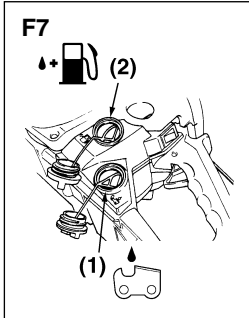

■ STARTING THE ENGINE

1. Fill fuel and chain oil tanks respectively, and tighten the caps securely. (F7)

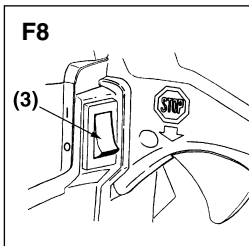

2. Set the switch to "I" position. (F8)

- (1) Chain oil
- (2) Fuel
- (3) Switch
- (4) Throttle lever
- (5) Throttle interlock

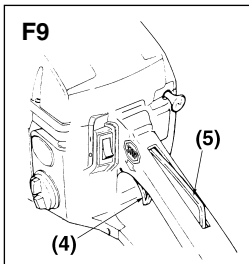

3. Pull out the choke knob to the second-stage position. The choke will close and the throttle lever will then be set in the starting position [F10-(a)].

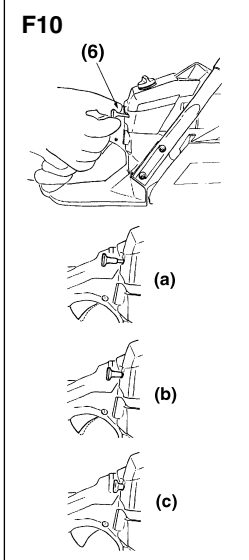

- (6) Choke knob

📖 NOTE

When restarting immediately after stopping the engine, set the Choke knob in the first-stage position (choke open and throttle lever in the starting position).

📖 NOTE

Once the choke knob has been pulled out, it will not return to the operating position even if you press down on it with your finger. When you wish to return the choke knob to the operating position, pull out the throttle lever instead.

F11

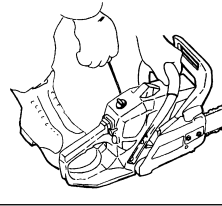

4. While holding the saw unit securely on the ground, pull the starter rope vigorously. (F11)

⚠ WARNING

Do not start the engine while the chain saw hangs in one hand. The saw chain may touch your body. This is very dangerous.

5. When engine has ignited, first push in the choke knob to the first-stage position and then pull the starter again to start the engine.
6. Allow the engine to warm up with the throttle lever pulled slightly.

⚠ WARNING

Keep clear of the saw chain as it will start rotating upon starting of engine.

■ CHECKING THE OIL SUPPLY

⚠ WARNING

Make sure to set up the bar and the chain when checking the oil supply. If not, the rotating parts may be exposed. It is very dangerous.

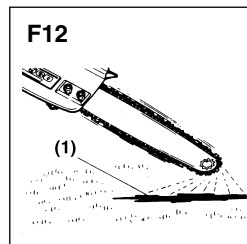

After starting the engine, run the chain at medium speed and see if chain oil is scattered off as shown in the figure. (F12)

- (1) Chain oil

📖 NOTE

The oil tank should become nearly empty by the time fuel is used up. Be sure to refill the oil tank every time when refueling the saw.

8. Operation

■ ADJUSTING THE CARBURETOR (F14)

The carburetor on your unit has been factory adjusted, but may require fine tuning due to a change in operating conditions.

Before adjusting the carburetor, make sure that the provided air/fuel filters are clean and fresh and the fuel properly mixed.

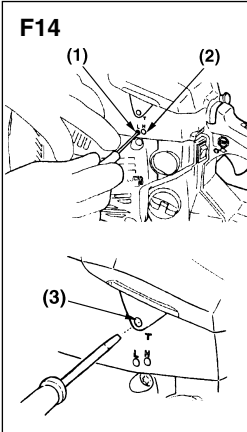

When adjusting, take the following steps:

NOTE

Be sure to adjust the carburetor with the bar chain attached.

1. H and L needles are restricted within the number of turn as shown below.

H needle	-1/4
L needle	-1/4
2. Start the engine and allow it to warm up in low speed for a few minutes.
3. Turn the idle adjusting screw (T) counterclockwise so that the saw chain does not turn. If the idling speed is too slow, turn the screw clockwise.
4. Make a test cut and adjust the H needle for best cutting power, not for maximum speed.

- (1) L needle
 (2) H needle
 (3) Idle adjusting screw

■ CHAIN BRAKE

This machine is equipped with an automatic brake to stop saw chain rotation upon occurrence of kickback during saw cutting. The brake is automatically operated by inertial force, which acts on the weight fitted inside the front guard.

This brake can also be operated manually with the front guard turned down to the guide bar.

To release the brake, pull up the front guard toward the front handle till a "click" sound is heard. (F15)

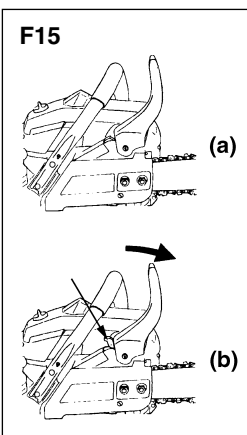

IMPORTANT

[Caution]

Be sure to confirm brake operation during daily inspection.

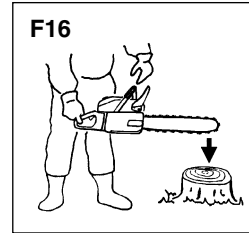

How to confirm:

- 1) Turn off the engine.
- 2) Holding the chain saw horizontally, release your hand from the front handle, hit the tip of the guide bar to a stump or a piece of wood, and confirm brake operation. Operating level varies by bar size. (F16)

In case the brake is not effective, ask our dealer inspection and repairing.

The engine, if being kept rotated at high speed with the brake engaged, heats the clutch, causing a trouble.

When the brake is operated while in operation, immediately release your fingers from the throttle lever and stop the engine.

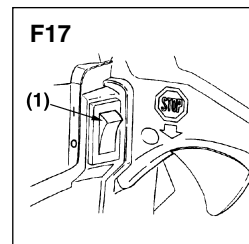

■ STOPPING THE ENGINE

1. Release the throttle lever to allow the engine to idle for a few minutes.
2. Set the switch to the "O" (STOP) position. (F17)

(1) Switch

Carburetor anti-freeze mechanism

Operating the chain saws in temperatures of 0–5°C at times of high humidity may result in ice forming within the carburetor, and this in turn may cause the output power of the engine to be reduced or for the engine to fail to operate smoothly.

This product has accordingly been designed with a ventilation hatch on the right side of the surface of the cylinder cover to allow warm air to be supplied to the engine and to thereby prevent icing from occurring.

Under normal circumstances the product should be used in normal operating mode, i.e., in the mode to which it is set at the time of shipment. However when the possibility exists that icing may occur, the unit should be set to operate in anti-freeze mode before use. (F18)

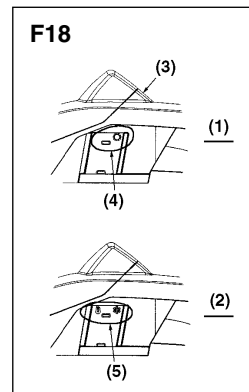

- (1) Normal operating mode
 (2) Anti-freeze mode
 (3) Cylinder cover
 (4) 'Sun shine' mark
 (5) 'Snow' mark

WARNING

Continuing to use the product in anti-freeze mode even when temperatures have risen and returned to normal may result in the engine failing to start

8. Operation

properly or in the engine failing to operate at its normal speed, and for this reason you should always be sure to return the unit to normal operating mode if there is no danger of icing occurring.

■ HOW TO SWITCH BETWEEN OPERATING MODES (F19)

1. Flip the engine switch to turn off the engine.
2. Remove the cover to the air filter, remove the air filter, and then remove the choke knob from the cylinder cover.
3. Loosen the screws holding the cylinder cover in place (i.e., the three screws on the inside and the one screw on the outside of the cover), and then remove the cylinder cover.
4. Press with your finger down on the icing cap located on the right-hand side of the cylinder cover to remove the icing cap.
5. Adjust the icing cap so that the "snow" mark faces upwards and then return it to its original position in the cylinder cover.
6. Fix the cylinder cover back into its original position, and then fix all other parts back into their proper positions.

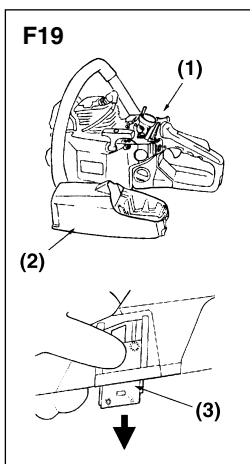

- (1) Choke knob
- (2) Cylinder cover
- (3) Icing cap

9. Sawing

⚠ WARNING

- Before proceeding to your job, read "For Safe Operation" section. It is recommended to first practice sawing easy logs. This also helps you get accustomed to your unit.
- Always follow the safety regulations. The chain saw must only be used for cutting wood. It is forbidden to cut other types of material. Vibrations and kickback vary with different materials and the requirements of the safety regulations would not be respected. Do not use the chain saw as a lever for lifting, moving or splitting objects. Do not lock it over fixed stands. It is forbidden to hitch tools or applications to the P.t.o. that are not specified by the manufacturer.
- It is not necessary to force the saw into the cut. Apply only light pressure while running the engine at full throttle.
- When the saw chain is caught in the cut, do not attempt to pull it out by force, but use a wedge or a lever to open the way.

■ GUARD AGAINST KICKBACK (F21)

- This saw is equipped with a chain brake that will stop the chain in the event of kickback if operating properly. You must check the chain brake operation before each usage by running the saw at full the throttle for 1 - 2 seconds and pushing the front hand guard forward. The chain should stop immediately with the engine at full speed. If the chain is slow to stop or does not stop, replace the brake band and clutch drum before use.
- It is extremely important that the chain brake be checked for proper operation before each use and that the chain be sharp in order to maintain the kickback safety level of this saw. Removal of the safety devices, inadequate maintenance, or incorrect replacement of the bar or chain may increase the risk of serious personal injury due to kickback.

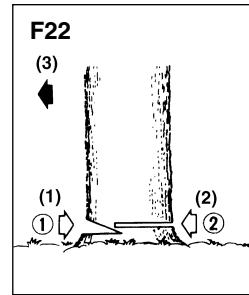
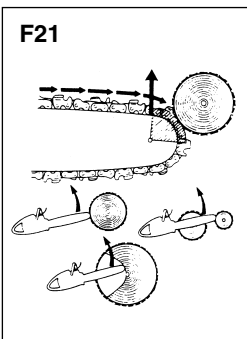

■ FELLING A TREE (F22)

1. Decide the felling direction considering the wind, lean of the tree, location of heavy branches, ease of job after felling and other factors.
2. While clearing the area around the tree, arrange a good foothold and retreat path.
3. Make a notch cut one-third of the way into the tree on the felling side.
4. Make a felling cut from the opposite side of the notch and at a level slightly higher than the bottom of the notch.

⚠ WARNING

When you fell a tree, be sure to warn your neighboring workers of the danger.

- (1) Notch cut
(2) Felling cut
(3) Felling direction

Bucking and Limbing

⚠ WARNING

- Always ensure your foothold. Do not stand on the log.
- Be alert to the rolling over of a cut log. Especially when working on a slope, stand on the uphill side of the log.
- Follow the instructions in "For Safe Operation" to avoid kickback of the saw.

Before starting work, check the direction of bending force inside the log to be cut. Always finish cutting from the opposite side of bending direction to prevent the guide bar from being caught in the cut.

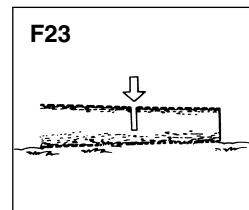

■ A Log lying on the ground (F23)

Saw down halfway, then roll the log over and cut from the opposite side.

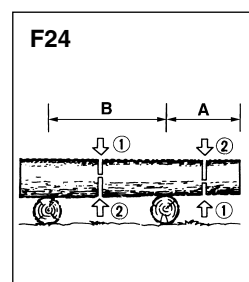

■ A Log hanging off the ground (F24)

In area A, saw up from the bottom one-third and finish by sawing down from the top. In area B, saw down from the top one-third and finish by sawing up from the bottom.

9. Sawing

F25

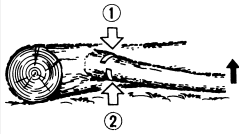

Cutting Limb of Fallen Tree (F25)

First check to which side the limb is bent. Then make the initial cut from the bent side and finish by sawing from the opposite side.

⚠ WARNING

Be alert to the springing back of a cut limb.

F26

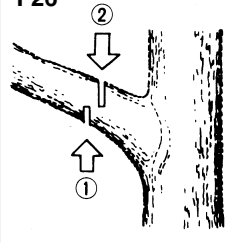

Pruning of Standing Tree (F26)

Cut up from the bottom, finish down from the top.

⚠ WARNING

- Do not use an unstable foothold or ladder.
- Do not overreach.
- Do not cut above shoulder height.
- Always use your both hands to grip the saw.

10. Maintenance

Maintenance, replacement, or repair of the emission control device and systems may be performed by any non-road engine repair establishment or individual.

⚠ WARNING

Before cleaning, inspecting or repairing your unit, make sure that engine has stopped and is cool. Disconnect the spark plug to prevent accidental starting.

■ MAINTENANCE AFTER EACH USE

1. Air filter

Dust on the cleaner surface can be removed by tapping a corner of the cleaner against a hard surface. To clean dirt in the meshes, split the cleaner into halves and brush in gasoline. When using compressed air, blow from the inside. (F27)

To assemble the cleaner halves, press the rim until it clicks.

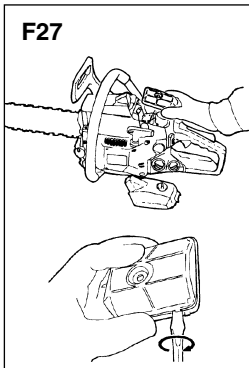

📖 NOTE

When installing the main filter, make sure that the grooves on the filter edge are correctly fit with the projections on the cylinder cover.

2. Oiling port

Dismount the guide bar and check the oiling port for clogging. (F28)

(1) Oiling port

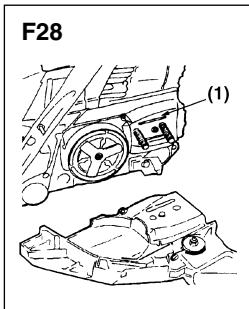

3. Guide bar

When the guide bar is dismounted, remove sawdust in the bar groove and the oiling port. (F29)

Grease the nose sprocket from the feeding port on the tip of the bar. (F30)

(1) Oiling port

(2) Grease port

(3) Sprocket

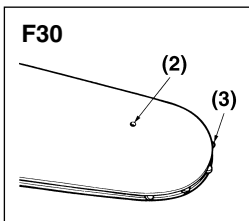
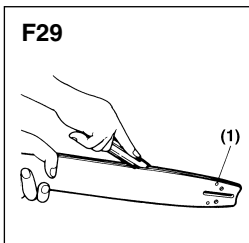

4. Others

Check for fuel leakage and loose fastenings and damage to major parts, especially handle joints and guide bar mounting and muffler. If any defects are found, make sure to have them repaired before operating again.

■ PERIODICAL SERVICE POINTS

1. Air cooling system

Dust clogging around the cooling system and the cylinder fins will cause overheating of the engine. Periodically check and clean the cooling system and the cylinder fins with a brush after removing the cylinder cover, the air cleaner and the recoil case. When installing the cylinder cover and the cooling system, make sure that switch wires and grommets are positioned correctly in place. (F31)

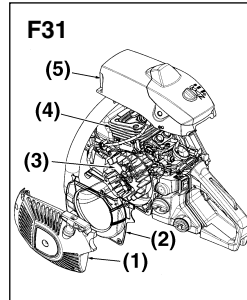

(1) Recoil case

(2) Fan cover

(3) Fan

(4) Cylinder fins

(5) Cylinder cover

📖 NOTE

Be sure to block the air intake hole.

2. Spark arrester

The muffler is equipped with a spark arrester to prevent red hot carbon from flying out of the exhaust outlet. Periodically check and clean as necessary with a wire brush after removing two muffler cover nuts and one screw. (F32)

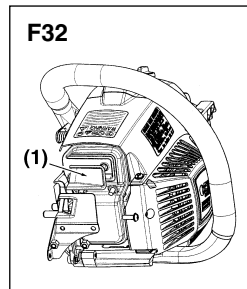

(1) Spark arrester

📖 NOTE

Never use a muffler if the spark arrester is missing or defective.

3. Exhaust port

Remove the muffler, insert a screwdriver into the vent, and wipe away any carbon buildup after every 100 hours of use. Wipe away any carbon buildup on the muffler exhaust vent and the cylinder exhaust port at the same time. (F33)

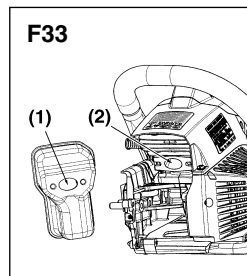

(1) Muffler exhaust vent

(2) Cylinder exhaust port

10. Maintenance

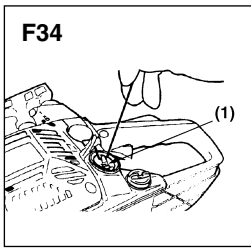

2. Fuel filter

(a) Using a wire hook, take out the filter from the filler port. (F34)

(1) Fuel filter

(b) Disassemble the filter and wash with gasoline, or replace with new one if needed.



NOTE

- After removing the filter, use a pinch to hold the end of the suction pipe.
- When assembling the filter, take care not to allow filter fibers or dust inside the suction pipe.

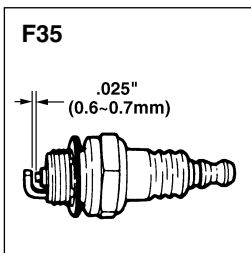

4. Spark plug

Clean the electrodes with a wire brush and reset the gap to .025in as necessary. (F35)

**Champion
RZ7C**

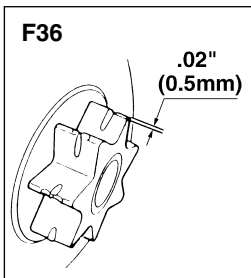

5. Sprocket

Check for cracks and for excessive wear interfering with the chain drive. If the wearing is found obviously, replace it with new one. Never fit a new chain on a worn sprocket, or a worn chain on a new sprocket. (F36)

11. Maintenance of Saw Chain and Guide Bar

SAW CHAIN



It is very important for smooth and safe operation to keep the cutters always sharp.

Your cutters need to be sharpened when:

- Sawdust becomes powder-like.
- You need extra force to saw in.
- The cut way does not go straight.
- Vibration increases.
- Fuel consumption increases.

Cutter setting standards:



Be sure to wear safety gloves.

Before filing:

- Make sure the saw chain is held securely.
- Make sure the engine is stopped.
- Use a round file of proper size for your chain.

Chain type: 91VG
File size: 5/32 in (4.0 mm)

Place your file on the cutter and push straight forward. Keep the file position as illustrated. (F37)

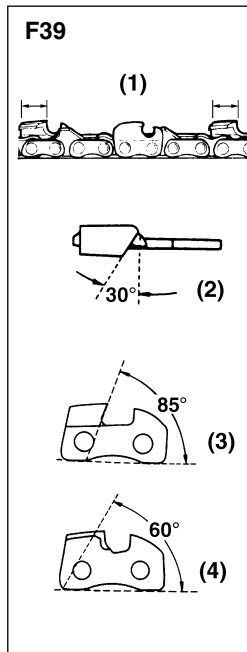
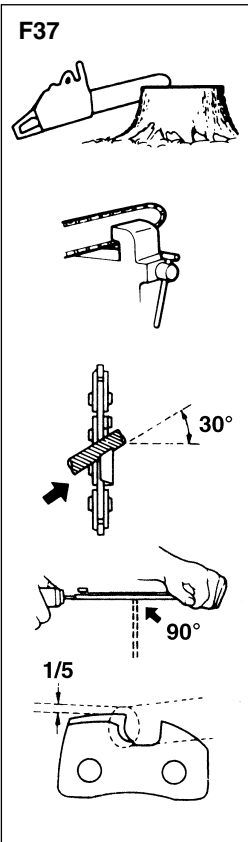

Make sure every cutter has the same length and edge angles as illustrated. (F39)

- (1) Cutter length
- (2) Filing angle
- (3) Side plate angle
- (4) Top plate cutting angle

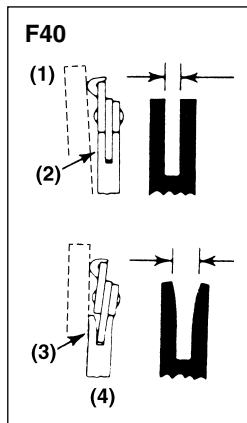

GUIDE BAR

- Reverse the bar occasionally to prevent partial wear.
- The bar rail should always be a square. Check for wear of the bar rail. Apply a ruler to the bar and the outside of a cutter. If a gap is observed between them, the rail is normal. Otherwise, the bar rail is worn. Such a bar needs to be corrected or replaced. (F40)

- (1) Ruler
- (2) Gap
- (3) No gap
- (4) Chain tilts

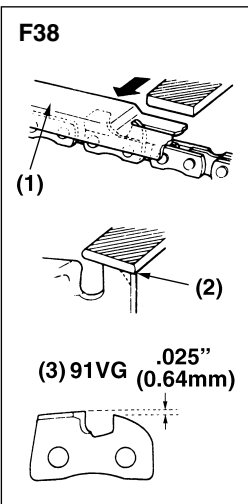

After every cutter has been set, check the depth gauge and file it to the proper level as illustrated. (F38)



Be sure to round off the front edge to reduce the chance of kickback or tie-strap breakage.

- (1) Appropriate gauge checker
- (2) Make the shoulder round
- (3) Depth gauge standard



This saw is equipped with one of the following low kickback bar/chain combinations:

Model GZ4000

14" Bar :	Oregon	140SPEA041
14" Chain :	Oregon Doubleguard	91VG052X

U
S

12. Storage

- Aged fuel is one of major causes of engine starting failure. Before storing the unit, empty the fuel tank and run the engine until it uses all the fuel left in the fuel line and the carburetor. Store the unit indoor taking necessary measures for rust prevention.

13. Disposal

- When disposing your machine, fuel or oil for the machine, be sure to allow your local regulations.

14. Troubleshooting guide

Case 1. Starting failure



Make sure the icing prevention system is not working.

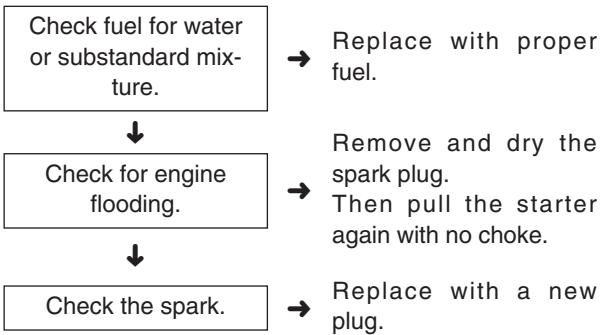

Case 2. Lack of power/Poor acceleration/ Rough idling

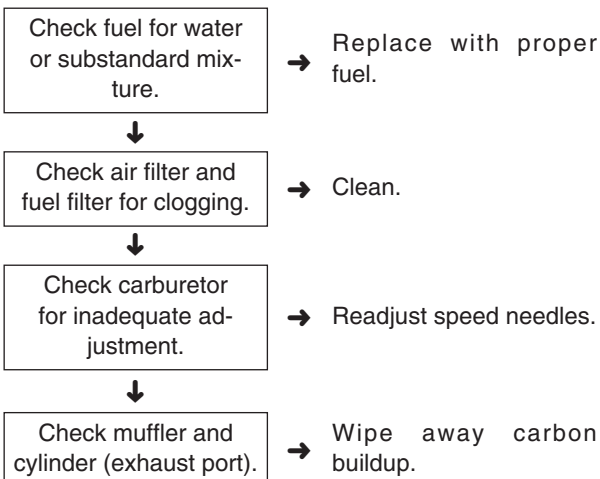

Case 3. Oil does not come out

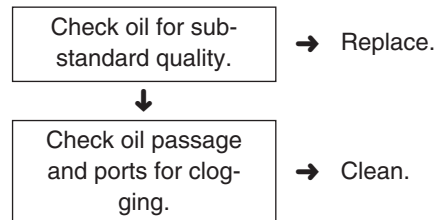

When your unit seems to need further service, please consult with our service shop in your area.

FEDERAL AND CALIFORNIA EMISSIONS CONTROL WARRANTY
STATEMENT YOUR WARRANTY RIGHTS AND OBLIGATIONS

The EPA (U.S. Environmental Protection Agency), CARB (California Air Resources Board), Environment Canada and RedMax are pleased to explain the emissions control system's warranty on your 2009 and later small off-road engine. In U.S. and Canada, new equipment that use small off-road engines must be designed, built, and equipped to meet the applicable Federal or Californian stringent anti-smog standards. RedMax must warrant the emissions control system on your small off-road engine for the period listed below provided there has been no abuse, neglect or improper maintenance of your equipment. Your emissions control system may include parts such as carburetor, ignition system, catalytic converter, fuel tank, filters and other associated components. Also, included may be hoses, belts, connectors, sensors, and other emission-related assemblies. Where a warrantable condition exists, RedMax will repair your small off-road engine at no cost to you including diagnosis, parts and labor.

MANUFACTURER'S WARRANTY COVERAGE

This emissions control system is warranted for two years or if the product qualifies for a longer warranty period resulting from the type of use, that period shall prevail. If any emissions-related part on your equipment is defective, the part will be repaired or replaced by RedMax.

OWNER'S WARRANTY RESPONSIBILITIES

As the small off-road engine owner, you are responsible for performance of the required maintenance listed in your Owner's Manual. RedMax recommends that you retain all receipts covering maintenance on your small off-road engine, but RedMax cannot deny warranty solely for the lack of receipts or your failure to ensure the performance of all scheduled maintenance. As the small off-road engine owner, you should however be aware that the RedMax may deny you warranty coverage if your small off-road engine or a part has failed due to abuse, neglect, or improper maintenance or unapproved modifications.

You are responsible for presenting your small off-road engine to a RedMax distribution center or service center as soon as the problem exists. The warranty repairs should be completed in a reasonable amount of time, not to exceed 30 days. If you have any questions regarding your warranty coverage, you should contact RedMax at 1-800-291-8251 or via e-mail at service@redmax.com.

WARRANTY COMMENCEMENT DATE

The warranty period begins on the date the engine or equipment is delivered to an ultimate purchaser.

LENGTH OF COVERAGE

RedMax warrants to the ultimate purchaser and each subsequent owner that the engine or equipment is designed, built, and equipped so as to conform with all applicable regulations adopted by EPA and CARB, and is free from defects in materials and workmanship that causes the failure of a warranted part for a period of two years.

WHAT IS COVERED

REPAIR OR REPLACEMENT OF PARTS Repair or replacement of any warranted part under the warranty must be performed at no charge to the owner at a warranty station. Warranty services or repairs will be provided at all RedMax distribution centers that are franchised to service the subject engines. Throughout the emissions warranty period of two years, RedMax must maintain a supply of warranted parts sufficient to meet the expected demand for such parts.

WARRANTY PERIOD Any warranted part that is scheduled for replacement as required in the maintenance schedule, is warranted for the period of time prior to the first scheduled replacement point for that part. If the part fails prior to the first scheduled replacement, the part will be repaired or replaced by RedMax at no cost. Any such part repaired or replaced under warranty is warranted for the remainder of the period prior to the first scheduled replacement point for the part. Any warranted part that is not scheduled for replacement as required in the maintenance schedule, is warranted for two years or if the product qualifies for a longer warranty period resulting from the type of use, that period shall prevail. If any such part fails during the period of warranty coverage, it will be repaired and replaced by RedMax at no cost. Any such part repaired or replaced under the

warranty is warranted for the remaining warranty period. Any warranted part that is scheduled only for regular inspection in the maintenance schedule will be warranted for a period of two years. A statement in such written instructions to the effect of "repair or replace as necessary" will not reduce the period of warranty coverage. Any such part repaired or replaced under warranty will be warranted for the remaining warranty period.

DIAGNOSIS The owner must not be charged for diagnostic labor that leads to the determination that a warranted part is in fact defective, provided that such diagnostic work is performed at a warranty station.

CONSEQUENTIAL DAMAGES RedMax is liable for damages to other engine components proximately caused by a failure under warranty of any warranted part.

EMISSION WARRANTY PARTS LIST

1. Air-induction system*
 2. Fuel system*
 3. Ignition system*
 4. Fuel tank, cap and lines as applicable*
- *some components only covered up to point specified by maintenance schedule

WHAT IS NOT COVERED

All failures caused by abuse, neglect or improper maintenance are not covered.

ADD-ON OR MODIFIED PARTS

Add-on or modified parts that are not exempted by CARB or EPA may not be used. The use of any non-exempted add-on or modified parts will be grounds for disallowing a warranty claim. RedMax will not be liable to warrant failures of warranted parts caused by the use of a non-exempted add-on or modified part.

HOW TO FILE A CLAIM

If you have any questions regarding your warranty rights and responsibilities, you should contact your nearest authorized servicing dealer or contact RedMax at 1-800-291-8251 or via e-mail at service@redmax.com.

WHERE TO GET WARRANTY SERVICE

Warranty services or repairs are provided through all RedMax authorized servicing dealers.

MAINTENANCE, REPLACEMENT AND REPAIR OF EMISSION-RELATED PARTS

Any replacement part may be used in the performance of any warranty maintenance or repairs and must be provided without charge to the owner. Such use will not reduce the warranty obligations of the manufacturer.

MAINTENANCE STATEMENT

The owner is responsible for the performance of all required maintenance, as defined in the operator's manual.